

WBK | Compression(column) Load Cell



DESCRIPTION

WBK is a column, stainless steel compression Load Cell designed for hopper, tank and truck scales. A large range of capacities is available. Hermetic sealing and built-in surge protection ensure that this product can be used in harsh environment.

SPECIFICATION

Capacity(R.L.)		tf	10, 20, 25, 30, 50, 100	
Rated output(R.O.)	mV / V		2.0 ± 0.005	
Zero balance	mV / V		0.0 ± 0.020	
Accuracy Class	-		D3	C3
Non-linearity	% R.O.		≤ 0.03	≤ 0.02
Hysteresis	% R.O.		≤ 0.03	≤ 0.02
Combined Error	% R.O.		≤ 0.03	≤ 0.02
Repeatability	% R.O.		≤ 0.02	≤ 0.01
Creep for 30min	% R.O.		≤ 0.03	≤ 0.017
Return for 30min	% R.O.		≤ 0.03	≤ 0.017
Resolution	-		≤ 1/3000	≤ 1/5000
Division	mV / V		0.00067	0.0004
Temperature effect on	- Zero Value	%/10°C	≤ 0.03	≤ 0.014
	- Output value	%/10°C	≤ 0.03	≤ 0.011
Excitation	- Recommended	V	10	
	- Maximum	V	15	
Resistance	- Input	Ω	350 ± 3.5	
	- Output	Ω	350 ± 3.5	
	- Insulation	MΩ	> 2000	
Comensated Temperature Range		°C	-10 to +40	
Operating Temperature Range		°C	-40 to +70	
Material & Plate		-	Stainless steel	
Cable specification		-	Ø8 x 4P x 10M & Ø8 x 4P x 25M (P.V.C)	
Platform size		-	Ø8 x 6P x 12M (Urethane)	
Safety overload		% R.L.	150%	

Features

- ▶ Stainless steel construction
- ▶ Hermetically sealed
- ▶ IP68 protection
- ▶ Suitable for compression application
- ▶ OIML C3 approved
- ▶ Ex ia IIC T4 approved(Option)

Options

- ▶ Accessory set

Application

- ▶ Hopper and Tank scales
- ▶ Truck scales

DIMENSION

▲ 10tf~30tf

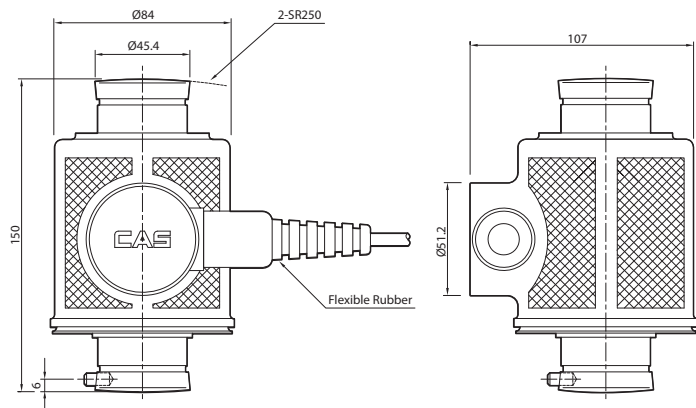

▼ 50tf~100tf

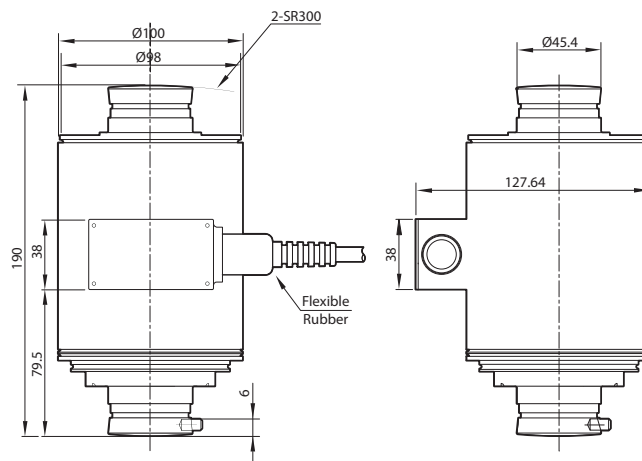

DIMENSION (WBK)

10tf-30tf ▶

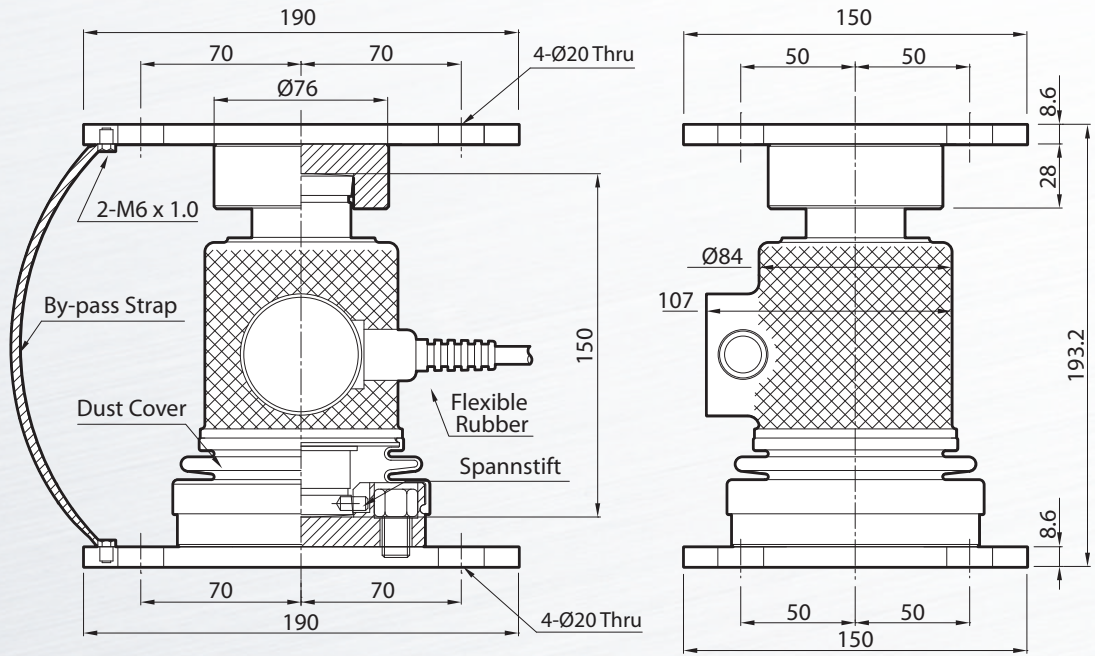

50tf-100tf ▶

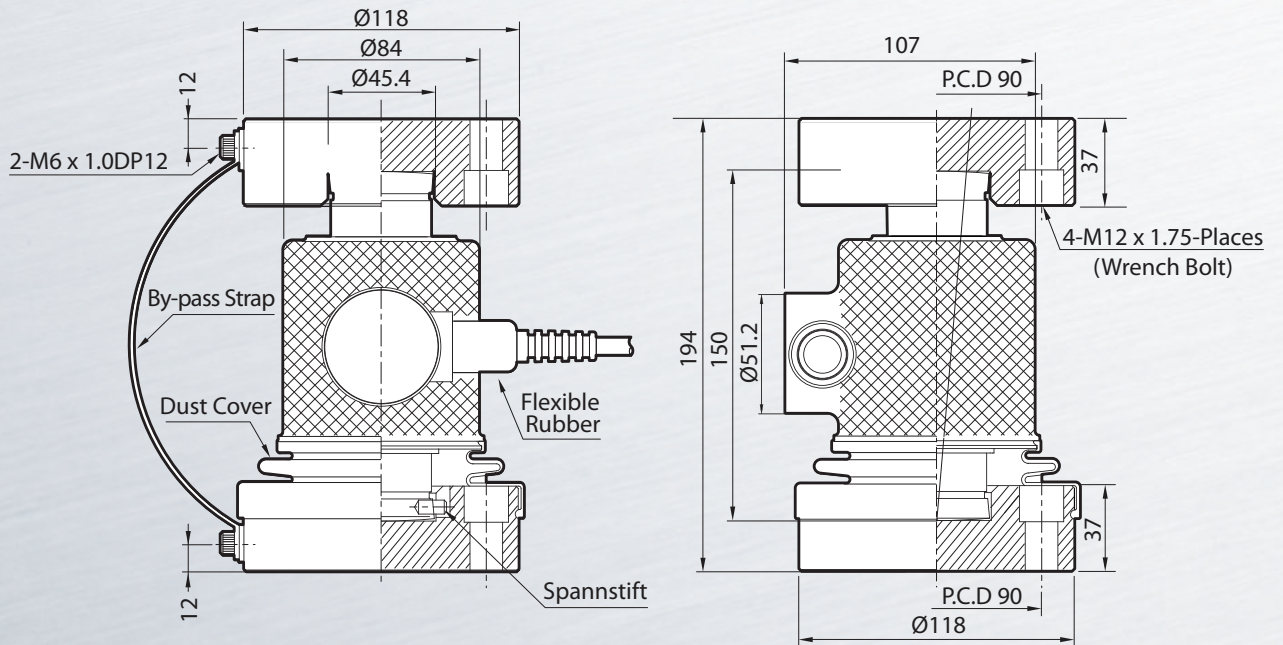

DIMENSION (WBK)

10tf-30tf ▶

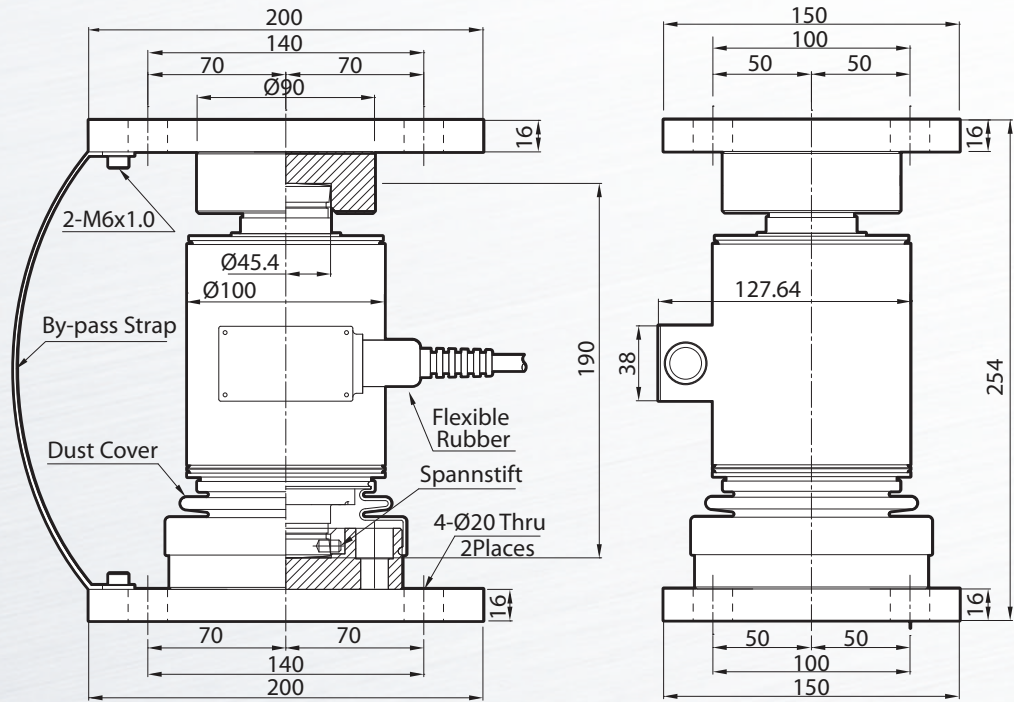

50tf-100tf ▶

